

Eclipse ThermJet

Burners

Model TJ0750
Version 2

PARAMETER	BURNER VELOCITY		MODEL TJ 0750
Maximum input Btu/hr (kW)	Medium & High Velocity		7,500,000 (2198)
Minimum Input, on-ratio Btu/hr (kW)	Medium & High Velocity		750,000 (220)
Minimum Input, fixed air Btu/hr (kW)	Medium & High Velocity		150,000 (44)
Gas inlet pressure required "w.c. (mbar) • Fuel pressure at gas inlet (Tap "B"– see page 3)	High Velocity	Nat. Gas Propane Butane	13.4 (33.4) 13.4 (33.4) 13.4 (33.4)
	Medium Velocity	Nat. Gas Propane Butane	6.7 (16.7) 6.7 (16.7) 6.7 (16.7)
Air inlet pressure required "w.c (mbar) • 15% excess air at maximum input (Tap "A" – see page 3)	High Velocity	Nat. Gas Propane Butane	16.6 (41.3) 16.6 (41.3) 16.6 (41.3)
	Medium Velocity	Nat. Gas Propane Butane	10.2 (25.4) 10.2 (25.4) 10.2 (25.4)
High Fire Flame Length Inches (mm) (measured from end of combustor)	High Velocity	Nat. Gas Propane Butane	100 (2540) 115 (2921) 110 (2794)
	Medium Velocity	Nat. Gas Propane Butane	125 (3175) 125 (3175) 130 (3302)
Maximum flame velocity ft/s (m/s) • 15% excess air, at maximum input	High Velocity		500 (152.4)
	Medium Velocity		250 (76.2)
Maximum combustion air temperature	300° F (149 °C) For higher temperatures, use TJPCA (Data 206)		
Flame detection	U.V. scanner only. (Available for all combustors.)		
Fuel	Natural Gas, Propane, Butane For any other mixed gas, contact Eclipse for orifice sizing.		

- All information is based on laboratory testing in neutral (0.0" w.c.) pressure chamber. Different chamber size and conditions may affect the data.
- All information is based on standard combustor design. Changes in the combustor will alter performance and pressures.
- All inputs based upon gross calorific values.
- Eclipse reserves the right to change the construction and/or configuration of our products at any time without being obliged to adjust earlier supplies accordingly.
- Plumbing of air and gas will affect accuracy of orifice readings. All information is based on generally acceptable air and gas piping practices.
- Do not install the burner with the gas inlet rotated 90° clockwise with respect to the air inlet if operating on natural gas using a flame rod.

Performance Graphs

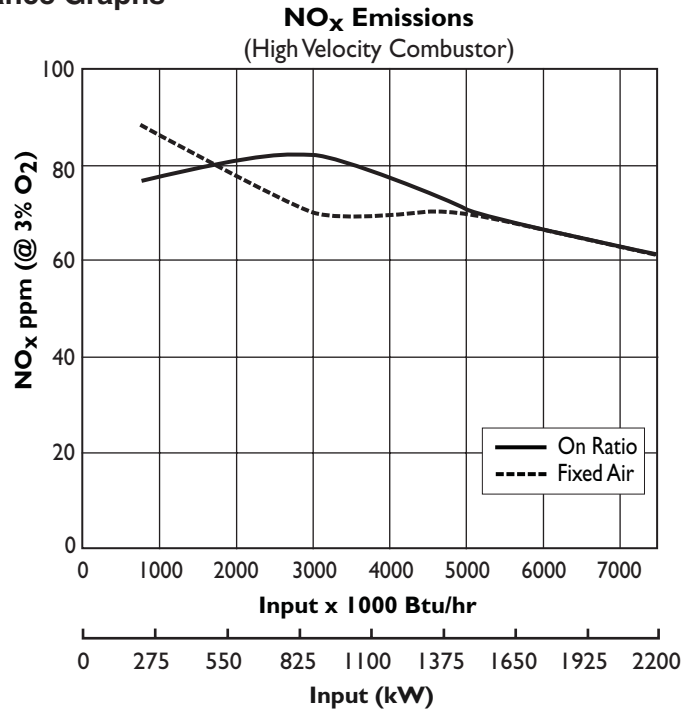
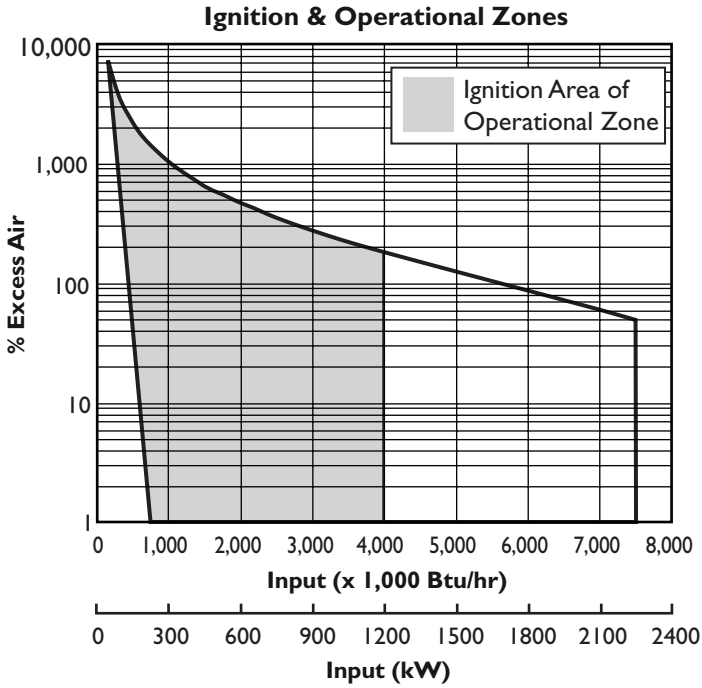

Correction factor for medium velocity combustor is 1.20
 Correction factor for propane or butane is 1.25
 Correction for both medium velocity and propane or butane is 1.50
 Fixed Air: High fire air is set to 3% O₂ and held constant while turning down the gas.
 On Ratio: Combustion air is adjusted to 3% O₂ at any given input.

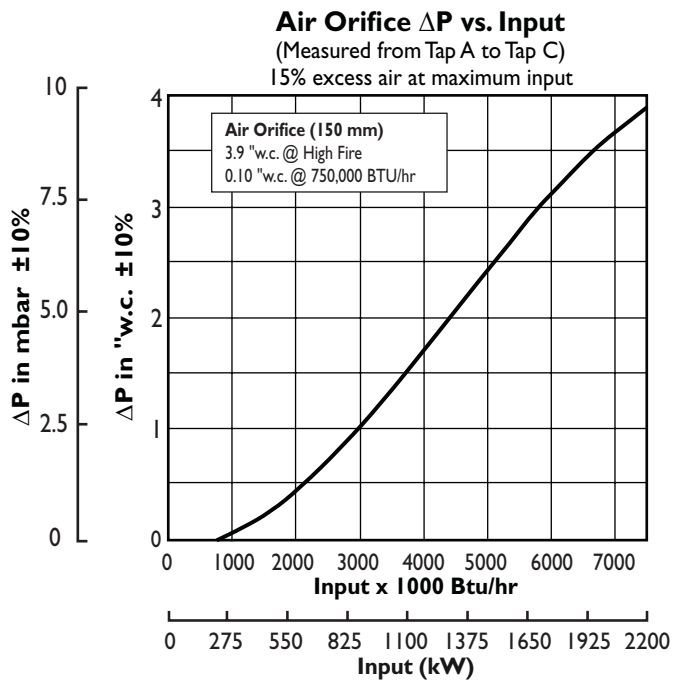
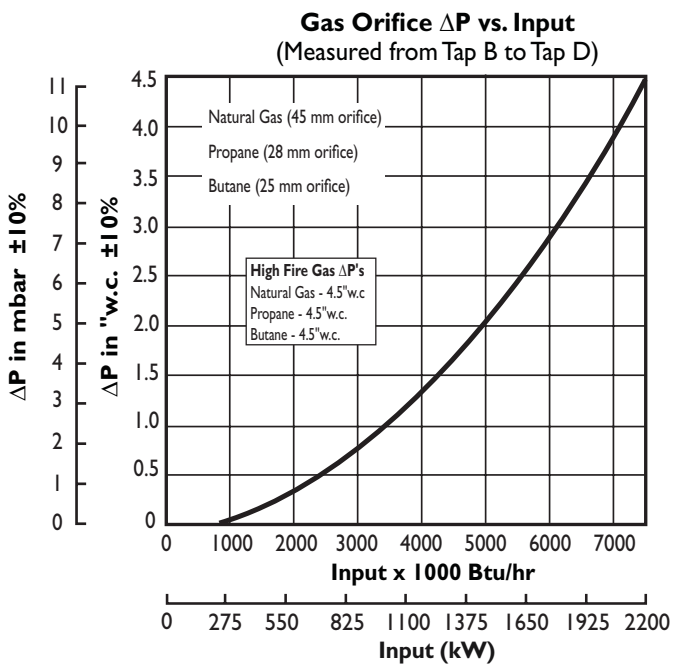

Dimensions & Specifications Millimeters (Inches)

Burner Housing

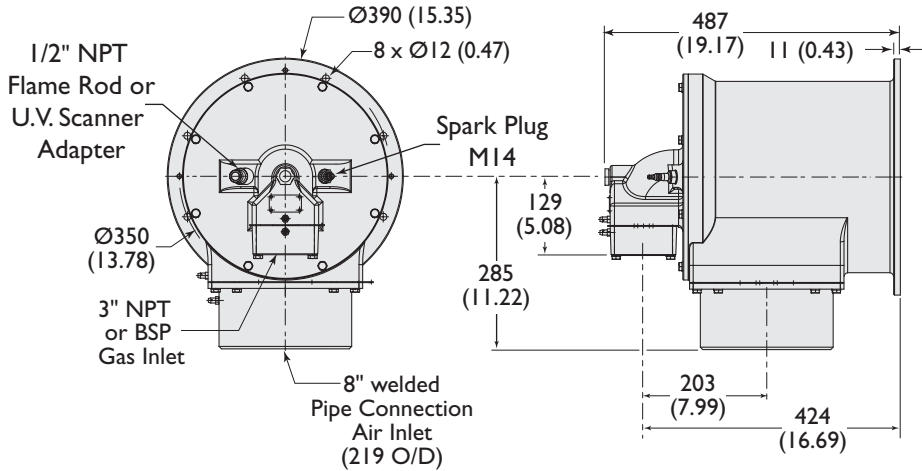

Burner weight less combustor: 133 lb (60 kg)

Tap Locations

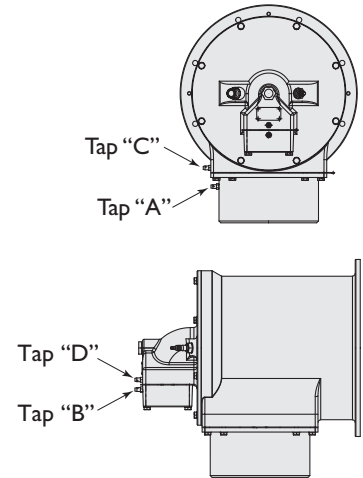

Combustor

Exhaust outlet diameter : High Velocity : $\text{Ø}155$ (6.10)
Medium Velocity : $\text{Ø}220$ (8.66)

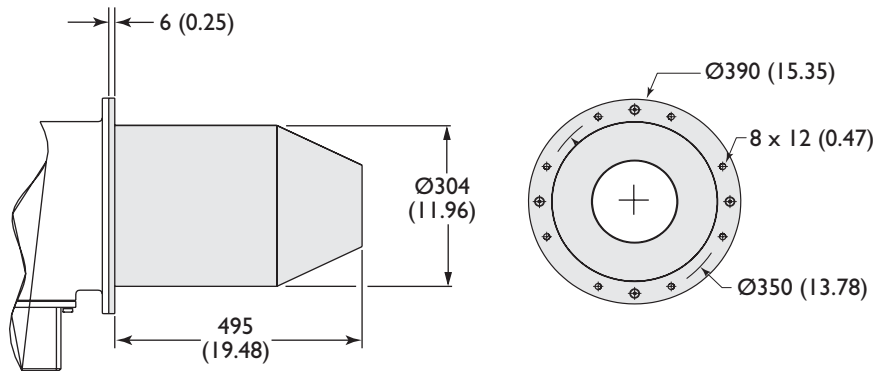

Alloy Tube (AISI 310)
Weight : 21 lb (9.5 kg)
Max. Chamber Temp : 1,750°F (950°C)

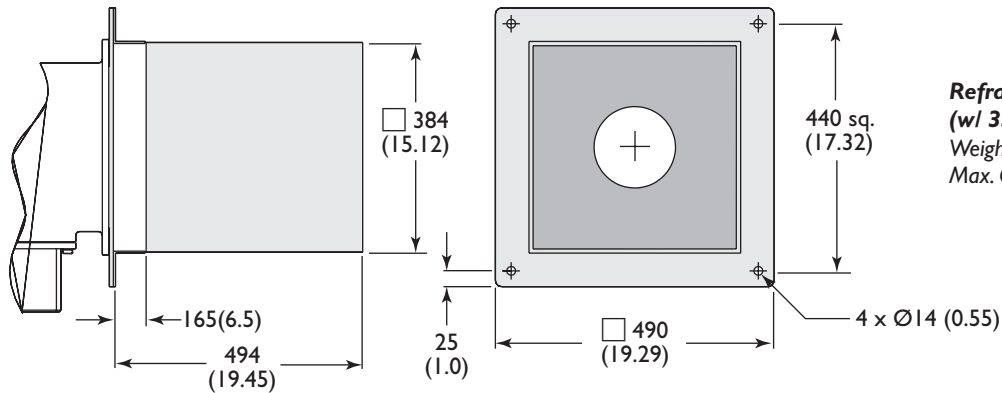

**Refractory Block
(w/ 330 SS wrapper)**
Weight : 330 lb (150 kg)
Max. Chamber Temp : 2,800°F (1,535°C)

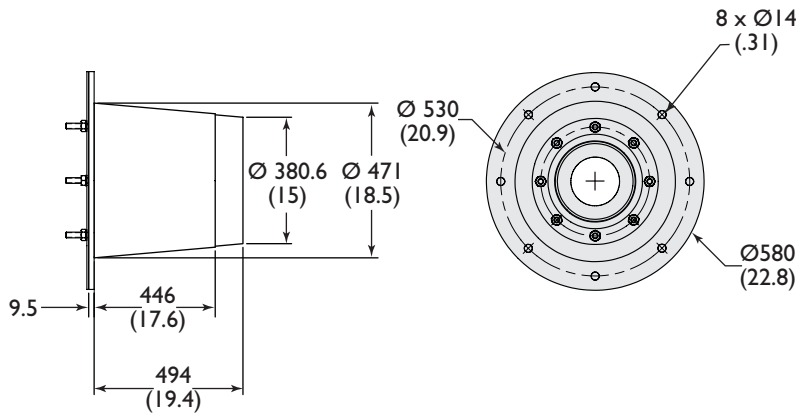

Down Firing Block

Weight: 310 lb (140.61 kg)

Max. Chamber Temp: 2800°F (1535°C)



Offered By:

Power Equipment Company
2011 Williamsburg Road
Richmond, Virginia 23231
Phone (804) 236-3800
Fax (804) 236-3882

www.peconet.com